

AIR LIFT
PERFORMANCE

Kit 78621

Ford Mustang S550

Rear Application



INSTALLATION GUIDE

For maximum effectiveness and safety, please read these instructions completely before proceeding with installation.

Failure to read these instructions can result in an incorrect installation.



TABLE OF CONTENTS

Introduction	2
Notation Explanation	2
Important Safety Notices	2
Installation Diagram	3
Hardware List	3
Installing the Air Suspension	4
Preparing the Vehicle	4
Removing the Rear Suspension	4
Air Suspension Installation	5
Before Operating	9
Setting the Ride Height	9
Torque Specifications	9
Suggested Driving Air Pressure and Maximum Air Pressure	9
Installation Checklist	10
Damping Adjustment	10
Limited Warranty and Return Policy	12



Introduction

Air Lift Performance thanks you for purchasing the most complete, fully engineered high-performance air suspension made for the Ford Mustang S550. Read these installation instructions to correctly and safely set up the vehicle for a #lifeonair.

Air Lift assumes that the installer has the mechanical knowledge and ability to work on vehicle suspension systems and has basic tools necessary to complete the project. Special tools needed to complete the installation are noted on the *Installation Diagram* page.

Air Lift reserves the right to make changes and improvements to its products and publications at any time. For the latest version of this manual, contact Air Lift Performance at (800) 248-0892 or visit www.airliftperformance.com.

An Air Lift Performance air management system is highly recommended for this product. Learn more at air-lift.co/productlines.

NOTATION EXPLANATION

Hazard notations appear in various locations in this publication. Information which is highlighted by one of these notations must be observed to help minimize risk of personal injury or possible improper installation which may render the vehicle unsafe. Notes are used to help emphasize areas of procedural importance and provide helpful suggestions. The following definitions explain the use of these notations as they appear throughout this guide.



DANGER

INDICATES IMMEDIATE HAZARDS WHICH WILL RESULT IN SEVERE PERSONAL INJURY OR DEATH.



WARNING

INDICATES HAZARDS OR UNSAFE PRACTICES WHICH COULD RESULT IN SEVERE PERSONAL INJURY OR DEATH.



CAUTION

INDICATES HAZARDS OR UNSAFE PRACTICES WHICH COULD RESULT IN DAMAGE TO THE MACHINE OR MINOR PERSONAL INJURY.

NOTE

Indicates a procedure, practice or hint which is important to highlight.

Important Safety Notices



WARNING

DO NOT INFLATE AIR SPRINGS WHILE OFF OF THE VEHICLE. DAMAGE TO ASSEMBLY MAY RESULT AND VOID WARRANTY.



CAUTION

DO NOT WELD TO OR MODIFY PERFORMANCE STRUTS/SHOCKS IN ANY WAY. DAMAGE TO UNIT MAY OCCUR AND WILL VOID WARRANTY.

Installation Diagram

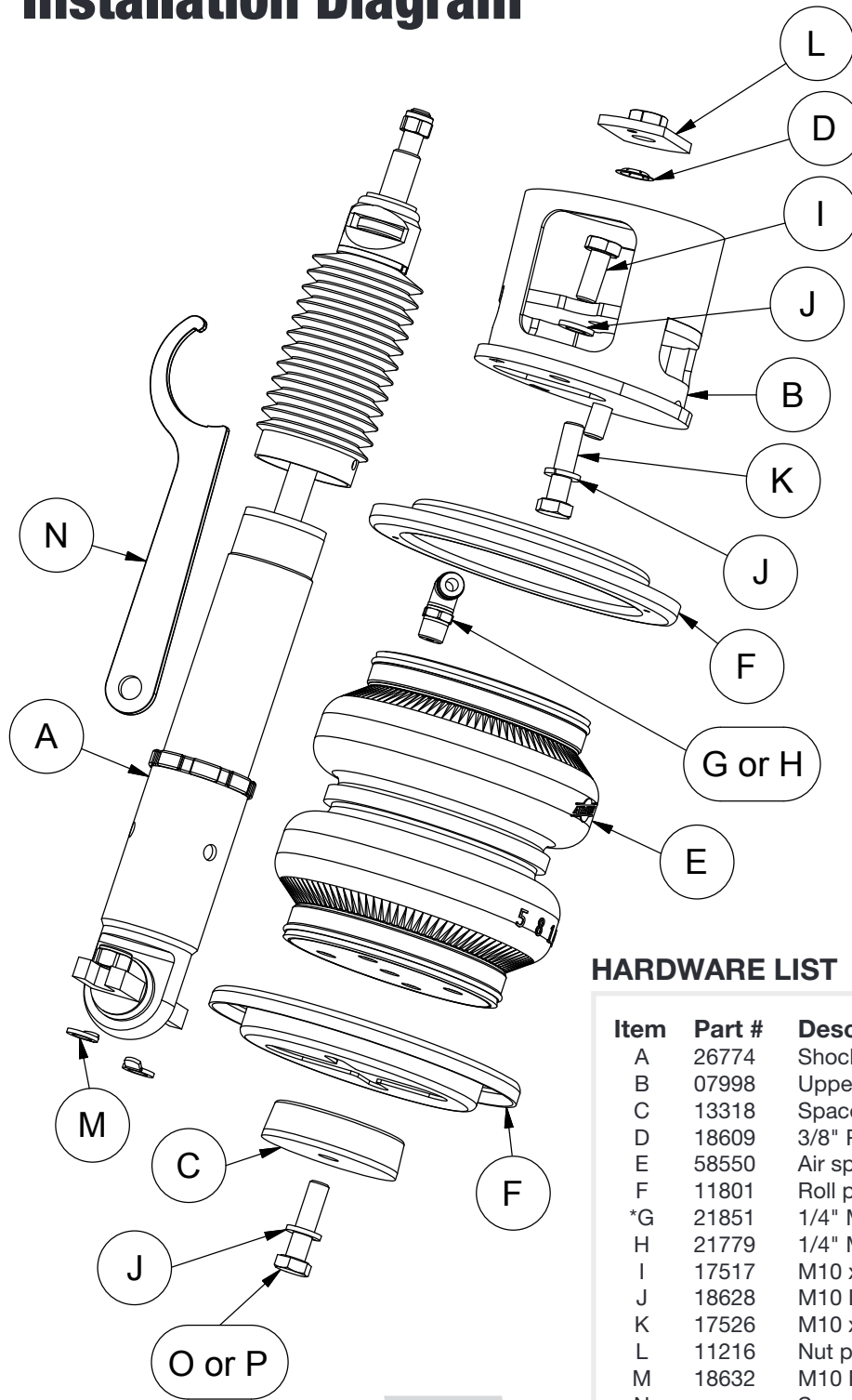

fig. 1

CAUTION

THIS KIT REQUIRES THE REMOVAL OF FACTORY TORQUE-TO-YIELD BOLTS. THESE BOLTS ARE DESIGNED TO BE REPLACED AFTER THEY HAVE BEEN LOOSENED. TORQUE-TO-YIELD BOLTS ARE INDICATED IN THE INSTRUCTIONS AND IN THE TORQUE SPECIFICATION CHART.

HARDWARE LIST

Item	Part #	Description	Qty
A	26774	Shock, Mustang (S550) rear	2
B	07998	Upper Bracket, Mustang (S550) rear	2
C	13318	Spacer, lowering centering	2
D	18609	3/8" Push nut.....	2
E	58550	Air spring, 2B6 reg, 1/4" - metric.....	2
F	11801	Roll plate.....	4
*G	21851	1/4" MNPT x 3/8" PTC, 90 degree	2
H	21779	1/4" MNPT x 1/4" PTC, 90 degree	2
I	17517	M10 x 1.5 x 25 Hex bolt	4
J	18628	M10 Lock washer	8
K	17526	M10 x 1.5 x 35 Hex bolt	2
L	11216	Nut plate - M10 x 1.5.....	2
M	18632	M10 Flag washer	4
N		Spanner wrench.....	1
O	17933	M10 x 1.5 x 40 Hex bolt	2
P	17936	M10 x 1.5 x 50 Hex bolt	2

*1/4" MNPT x 3/8" PTC fittings are NOT included in this kit, but are available as a special order.



Missing or damaged parts? Call Air Lift customer service at (800) 248-0892 for a replacement part.

Installing the Air Suspension

PREPARING THE VEHICLE

1. Elevate and support the vehicle with a hoist or safety stands.
2. Remove the rear wheel and support the hub assembly (Fig. 2).



fig. 2

REMOVING THE REAR SUSPENSION

1. Disconnect and remove the stabilizer bar end link from the bar and from the lower control arm (Fig. 3).



fig. 3

2. With the hub supported, unbolt the lower shock mount from the lower control arm (Figs. 4 & 5).

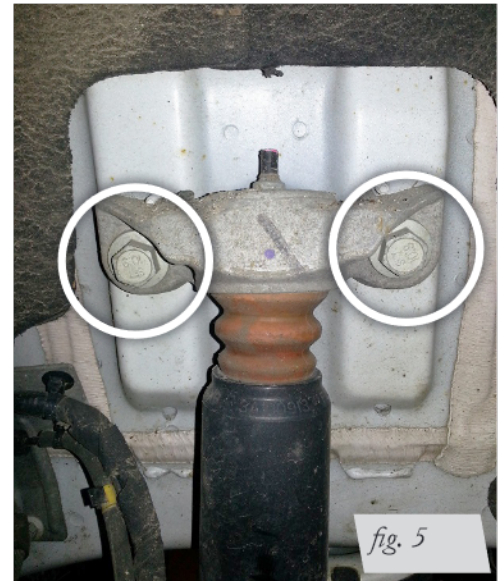
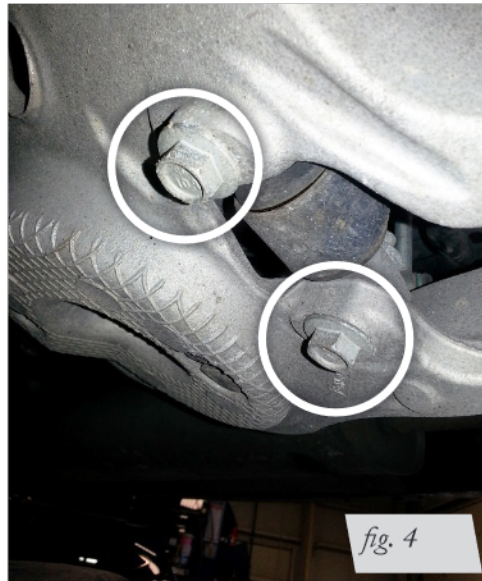

3. Unthread the two upper shock mount bolts and remove the shock from the vehicle.
4. Remove rear coil springs from vehicle.



CAUTION

COIL SPRINGS ARE UNDER SIGNIFICANT LOAD. PROCEED WITH CAUTION AND FOLLOW FACTORY INSTRUCTION FOR SAFE REMOVAL OF THE COIL SPRINGS.

AIR SUSPENSION INSTALLATION

1. Begin by installing the air fitting into the air spring (Fig. 6). Apply thread sealant to the threads of the air fitting. Tighten the appropriate fitting to the air spring 1 3/4 turns beyond hand-tight.

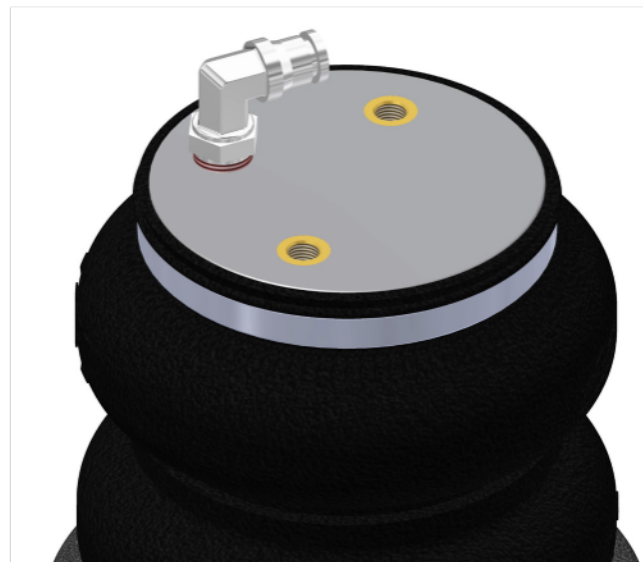

2. Insert long bolt (K) with lock washer (J) through the upper bracket center mounting hole (Fig. 7). Retain the bolt to the upper bracket (Figs. 8 & 9) using push nut (D).

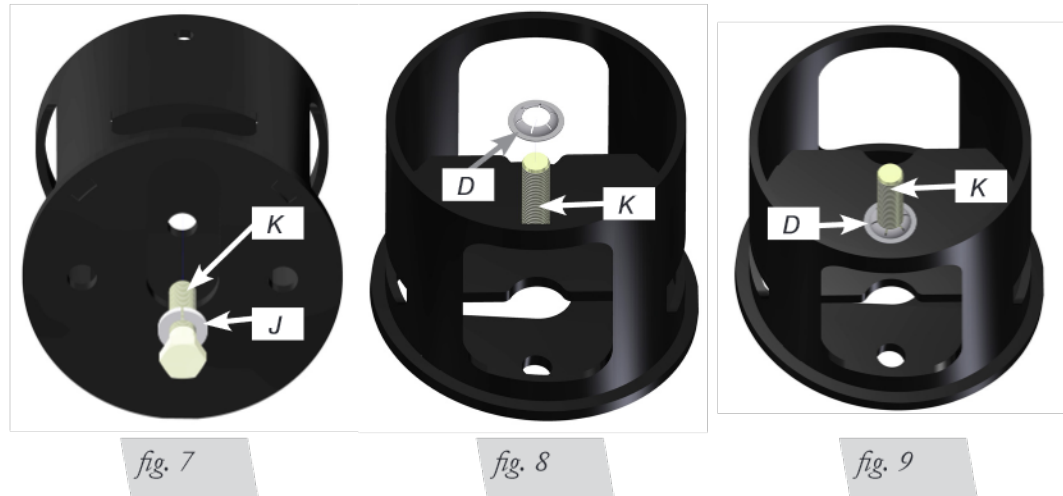

3. Place the roll plate (F) over the air spring (Fig. 10). Attach the upper mount to the air spring (Fig. 11) using two short bolts (I) and two lock washers (J). Torque to 27Nm (20 lb.-ft.)

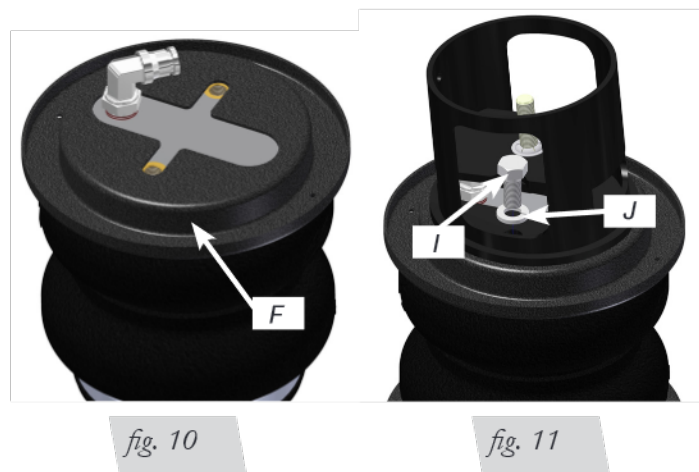

4. Insert the nut plate (L) into the opening within the upper spring perch with the flat of the plate facing downward, nut facing upward (Figs. 12 & 13).

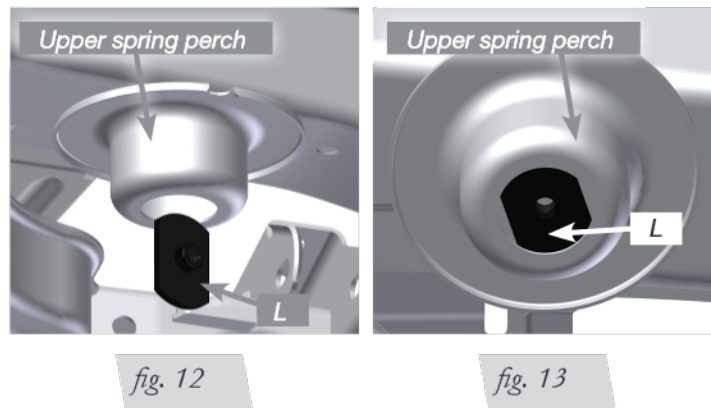

5. Apply the second roll plate (F) within the lower control arm spring pocket (Fig. 14).



fig. 14

6. Center the assembly over the upper spring perch, with the upper bracket sight hole aligned with the notch in the upper spring seat (Fig. 15). Thread the upper bracket bolt into the nut plate, torque to 27Nm (20 lb.-ft.).

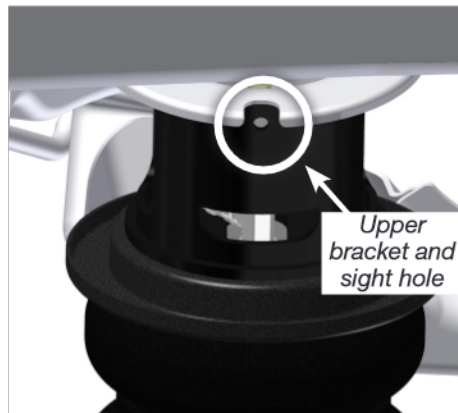

fig. 15

7. Seat the air spring within the lower control arm/roll plate and align the threaded center of the air spring with the lower spring seat. Apply a long bolt (P) FOR STANDARD MUSTANG, (O) FOR PERFORMANCE PACK MUSTANG and lock washer (J) through the centering spacer (C) and into the underside of the control arm (Fig. 16). Thread the bolt into the air spring (Fig. 17), and torque to 27Nm (20 lb.-ft.).

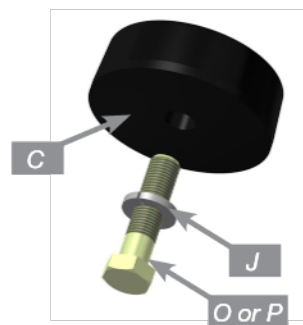

fig. 16

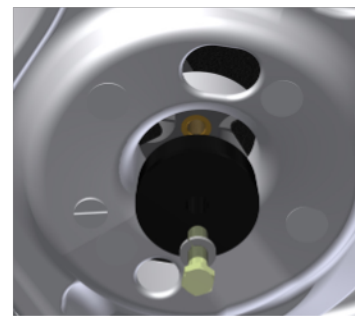
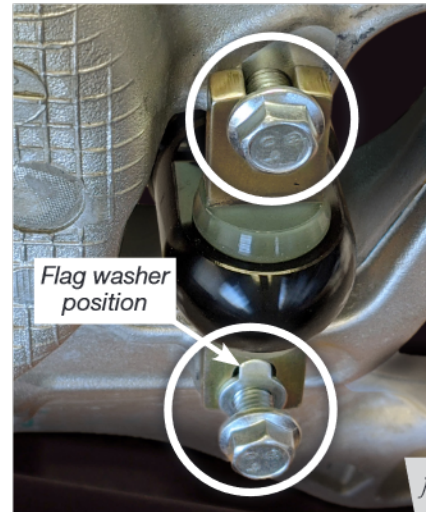

fig. 17

8. Swap the upper shock mounts from the OE shock to the new shock (Figs. 18-20). Torque rod nut to 27Nm (20 lb.-ft.) Attach the mount to the chassis, torque bolts to 90Nm (66 lb.-ft.).



9. For applications without MagneRide, bolt the shock to the lower control arm using the supplied nuts (Fig. 21a). Torque to 48Nm (35 lb.-ft.). For applications with MagneRide, bolt the shock to the underside of the control arm using the supplied M10 flag washers. Torque to 48Nm (35 lb.-ft.).



10. Reinstall the stabilizer bar end link opposite the way it was originally mounted with upper stud facing towards air spring (Fig. 22). Torque end link nuts to 103Nm (76 lb.-ft.).



Before Operating

SETTING THE RIDE HEIGHT

1. Refer to the User Guide supplied with this kit to set up the suspension.

Torque Specifications			
Location	TTY*	Nm	Lb.-ft.
Shock rod nut		27	20
Upper bracket bolt		27	20
Lower spring seat bolt		27	20
Stabilizer bar end link nut	✓	115	85
Upper shock mount to body bolts	✓	90	66
Lower shock mount to control arm	✓	48	35
Wheel studs		201	148
Air fitting (use thread sealant)		1 3/4 turns beyond hand-tight	

* Torque-to-yield bolts

Table 1



CAUTION

TORQUE-TO-YIELD BOLTS ARE DESIGNED TO BE REPLACED AFTER THEY HAVE BEEN LOOSENED.

Suggested Driving Air Pressure	Maximum Air Pressure
70 PSI (4.8BAR)	125 PSI (8.6BAR)
FAILURE TO MAINTAIN ADEQUATE MINIMUM PRESSURE (OR PRESSURE PROPORTIONAL TO LOAD) MAY RESULT IN EXCESSIVE BOTTOMING OUT AND WILL VOID THE WARRANTY.	

Table 2

INSTALLATION CHECKLIST

- Clearance** — Inflate the air springs to 75-90 PSI (5.2-6.2BAR) and make sure there is at least 1/2" (13mm) clearance from anything that might rub against the air spring. This should be checked with the air spring fully inflated and fully deflated.
- Leak** — Inflate the air springs to 75-90 PSI (5.2-6.2BAR) and check all connections for leaks. All leaks must be eliminated before the vehicle is road tested.
- Heat** — Be sure there is sufficient clearance from heat sources, at least 6" (152mm) from air springs and air lines. If a heat shield was included in the kit, install it. If there is no heat shield, but one is required, call Air Lift customer service at **(800) 248-0892**.
- Fastener** — Recheck all bolts for proper torque.
- Road** — Inflate the air springs to recommended driving pressures (Table 2). Drive the vehicle 10 miles (16km) and recheck for clearance, loose fasteners and air leaks.
- Operating instructions** — If professionally installed, the installer should review the operating instructions with the owner. Be sure to provide the owner with all paperwork that came with the kit.

DAMPING ADJUSTMENT

1. The dampers in this kit have 30 settings, or “clicks,” of adjustable compression and rebound damping characteristics. Damping is changed through the damper rod using the supplied adjuster (Fig. 23) or a 3mm hex key (not included).
2. Turn the adjuster clockwise (H) and the damping settings are hardened, reducing oscillations and body motion. Turn the adjuster counterclockwise (S) and the damping is softened.
3. Each damper in this kit is preset to “-15 clicks.” This means that the damper is adjusted 15 clicks away from full stiff, which starts at 0. Counting up from full stiff is the preferred method of keeping track of, or setting, damping. This setting was developed on a 2015 Ford Mustang 2.3L EcoBoost.

For more information, refer to the User Guide.

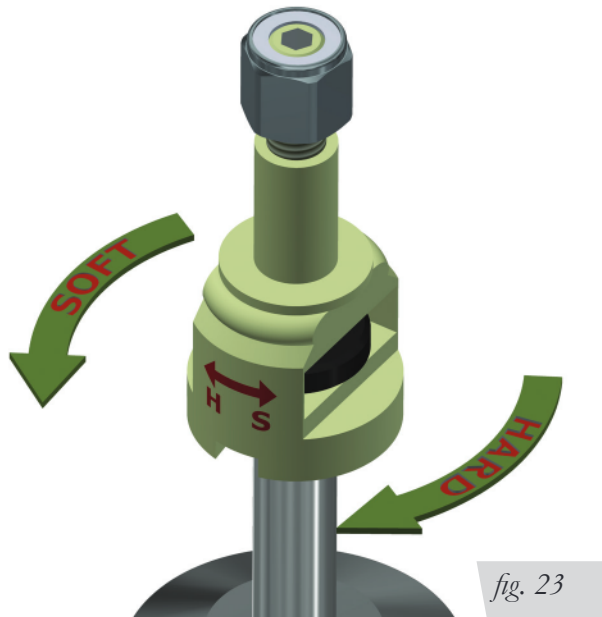

Notes

Limited Warranty and Return Policy

Air Lift Company provides a 1-year limited warranty* to the original purchaser of Air Lift Performance damper kits from the date of original purchase, that the products will be free from defects in workmanship and materials when used on cars and trucks as specified by Air Lift Company and under normal operating conditions, subject to the requirements and exclusions set forth in the full Limited Warranty and Return Policy.

* Full Limited Warranty and Return Policy are available at www.airliftperformance.com/support/warranty and are subject to change.

WARRANTY REGISTRATION & CLAIMS

- To register your warranty, please visit <https://www.airliftperformance.com/support/warranty-registration/>
- To submit a warranty claim, please visit <https://www.airliftperformance.com/support/submit-warranty-claim/>

NEED HELP?

Contact Air Lift Company customer service department by calling (800) 248-0892. For calls from outside the USA or Canada, dial (517) 322-2144.



Connect by searching for **Air Lift Performance** #LifeonAir



Thank you for purchasing Air Lift Performance products!



Air Lift Performance • 2727 Snow Road • Lansing, MI 48917 or P.O. Box 80167 • Lansing, MI 48908-0167
Toll Free (800) 248-0892 • Local (517) 322-2144 • Fax (517) 322-0240 • www.airliftperformance.com

Printed in the USA
JJC-0824

California: ⚠️WARNING: Cancer and Reproductive Harm - www.P65Warnings.ca.gov