

## LOWERING SPRING INSTALLATION INSTRUCTIONS – SPH767

### REAR SPRINGS:

1. Lift vehicle and safely support with jack stands under the rear cradle.

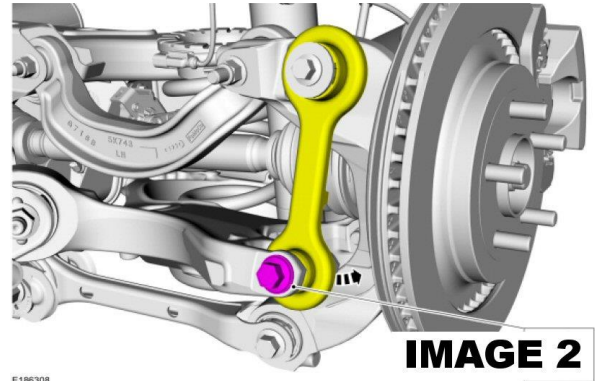
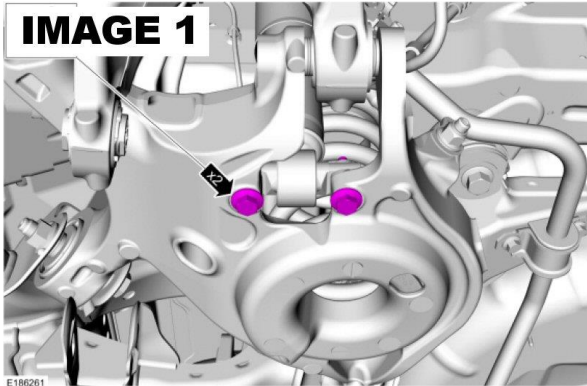

2. Remove the wheels/tires to gain access to the work area.
3. There are two ways to remove the rear springs. The easiest and quickest is by lowering the rear cradle but this is only really possible if you have access to a lift with roller jacks or a transmission jack and a few helpers. Because this option is not typically possible, this guide will follow Ford Service Manual recommendations and remove the

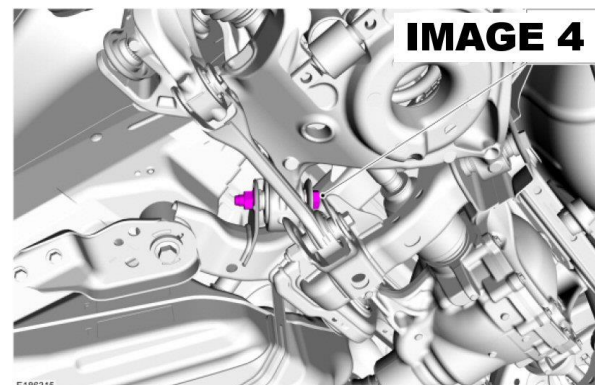
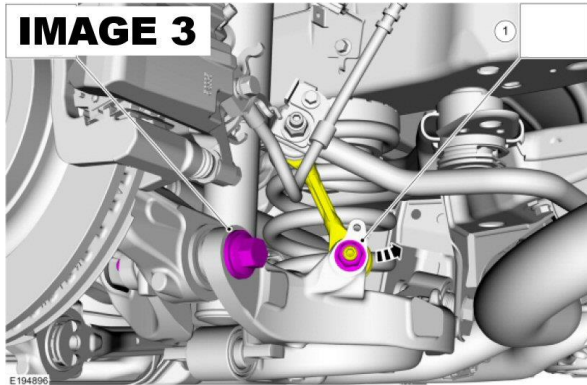

lower control arms to access the springs.

4. Remove the lower shock bolts. **(IMAGE 1)**
5. Remove the bottom bolt on the vertical link. **(IMAGE 2)**
6. Remove the lower sway bar end link nut. **(IMAGE 3)**
7. Remove the outer bolt on the lower control arm. **(IMAGE 3)**
8. Remove both inner bolts on the lower control arm. **(IMAGE 4)**
9. Remove the spring. **(IMAGE 5)**

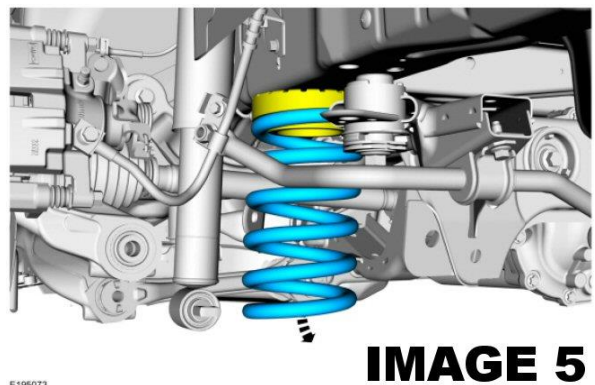



## LOWERING SPRING INSTALLATION INSTRUCTIONS (Cont.)=

10. Insert the BMR spring taking care to line up the ends of the spring coil with the spring seats on the top and bottom mounting points. **(IMAGE 6)**

**NOTE:** Take note of the BMR part numbers on the rear springs. Use Part #SPH766 for the passenger rear location and Part #SP085 for the drivers rear location.

11. Re-install the A-arm, sway bar end link, vertical link, and lower shock bolts but do not tighten any of the bolts at this time.

12. Once both springs are installed, the suspension must be loaded before tightening all of the suspension points. Failure to do so may result in premature bushing wear and inconsistent ride heights. The easiest way to load the suspension is to back the car up onto ramps and then tighten all of the suspension bolts.

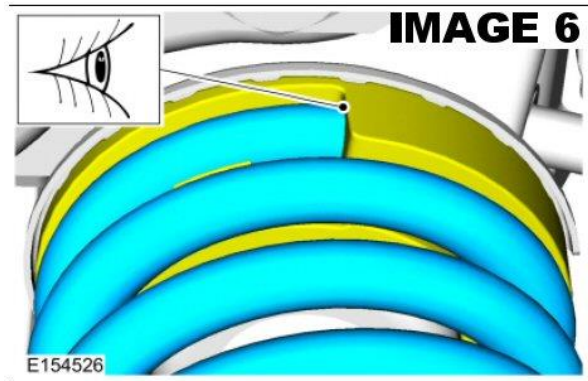

Tighten suspension bolts to the following specifications:

Lower shock bolts:	35 ft/lbs.
Lower vertical link bolt:	129 ft/lbs.
Rear inner lower control arm bolts:	184 ft/lbs.
Front inner lower control arm bolts:	166 ft/lbs.
Outer lower control arm bolts:	203 ft/lbs.

**NOTE:** Lowering springs will increase negative camber. To prevent premature tire wear, a 4 wheel alignment is recommended after the spring installation.

**WWW.BMRSUSPENSION.COM**

*This product is an aftermarket accessory and not designed by the vehicles manufacturer for use on this vehicle. As such, buyer assumes all risk of any damage caused to the vehicle/person during installation or use of this product.*